

Simple, reliable

Active1D[®] and autonomous

Early Streamer Emission lightning rod

Principle and operating

The **Active1D[®]** excitation advance is obtained by a device named « impulse device ». Its principle consists in storing electrostatic energy present in the atmosphere at a stormy cloud approach to release the ascending discharge excitation in a good time.

This device operates with an integrated sensor which measures the surrounding electrical field value.

It generates then a polarity inversion of the lightning rod head, creating a sudden amplification of the electrical field on its point.

Active1D[®] characteristics

- Consideration of the energy character to choose the streamer able to become an ascending leader,
- Autonomous and clean energy source : atmospheric electrical field,
- Cloud polarity consideration,
- Optimized head bending radius to reduce the corona effect and guarantee the excitation advance,
- Guarantee of functioning in all weather conditions,
- High resistance to corrosion thanks to its manufacture in 304 L stainless steel,
- In compliance with NFC 17-102 standard of September 2011

Active1D[®] radii of protection

The **Active1D[®]** has been tested in laboratory according to NFC 17-102 standard protocol.

These tests showed, according to models, excitation advances from 12 μ s to 60 μ s regarding to a simple rod.



Enhanced protection zone

The **Active 1D[®]** radii of protection here below mentioned, are defined for the four Np levels of protection (from I to IV) regarding to h real height between the lightning rod point and the highest point of the structure to protect.

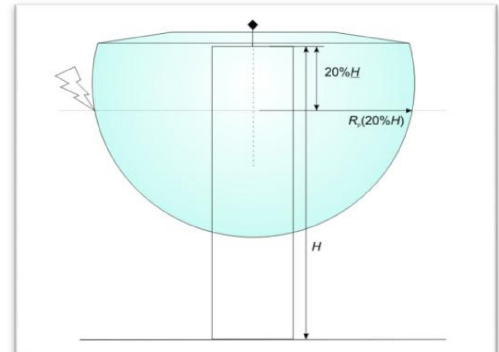

ΔT : Excitation advance, for **Active 1D[®]**, $\Delta T=12, 25, 45$ and $60\mu s$

- Np : level of protection with more or less severity (I to IV) determined by
- the lightning risk assessment with the Lightning Risk software according to NFC 17-102 standard,
- h(m) : height between the lightning rod point and the highest point of the structure to protect.

Active 1D [®] h (m)	Np	AFB10121D				AFB10251D				AFB10451D				AFB10601D			
		I	II	III	IV	I	II	III	IV	I	II	III	IV	I	II	III	IV
2		11	13	16	19	17	20	23	26	25	28	32	36	31	34	39	43
4		23	27	32	37	34	39	46	52	51	57	65	72	63	69	78	85
5		28	34	41	46	42	49	57	65	63	71	81	89	79	86	97	107
6		29	34	42	48	43	49	58	66	63	71	81	90	79	87	97	107
8		30	36	43	50	43	50	59	67	64	72	82	91	79	87	98	108
10		30	37	45	52	44	51	61	69	64	72	83	92	79	88	99	109
20		32	41	51	60	45	54	65	73	65	74	86	97	80	89	102	113
30		32	42	55	65	45	55	68	80	65	75	89	101	80	90	104	116

• Active 1D[®] range

Model	ΔT (μs)	Lightning counter
AFB10121D	12	Not included
AFB17121D	12	Included

Model	ΔT (μs)	Lightning counter
AFB10451D	45	Not included
AFB17451D	45	Included

Model	ΔT (μs)	Lightning counter
AFB10251D	25	Not included
AFB17251D	25	Included

Model	ΔT (μs)	Lightning counter
AFB10601D	60	Not included
AFB17601D	60	Included

Lightning counter
AFV0907CF



Active 1D[®] test

The **Active 1D[®]** can be tested on site with AFV0050TT wire test case (initial check, periodical checks according to NFC 17-102 standard and decrees in force, maintenance,...)

Simple and fast, this test can be done either disassembling the lightning rod, either using the AFV0087PT test perch, to check lightning rods at a height of 8 meters without dismantling.

This tester power supply operates with a battery (provided). The display with indicator lights indicates instantly the obtained result (positive or negative).



Wired tester
AFV0050TT

Packing

Complete lightning rod packed in reinforced cardboard box

- Weight : 3,00 Kg

- Dimensions : 430 x 110 x 110 mm